

REV.	DATE	ECN NO.	MODIFICATION	APPROVER
A0	2021.03.25		NEW	Abel
A1	2024.07.19	RD00324071902	外壳止位处塑胶加胶	Abel

Note:

- 1.Material:
 - 1.1 Housing: LCP,UL94V-0 Color:Black
 - 1.2 Contact: C7025,T=0.20mm,
1U"Min Gold plating at contact area
60U"Min Bright Tin plating at solder area
50U"Min Nickel under plating over all
 - 1.3 Shell: SUS316,T=0.15mm,
Nickel 50U"Min plated over all.
 - 1.4 Latch: SUS301,T=0.30mm
80U"Min Bright Tin plated over Ni 30U"Min
 - 2.Electrical:
 - 2.1 Current Rating:5A
 - 2.2 Voltage Rating:20V
 - 2.3 Contact Resistance:40mΩ Max
 - 2.4 Dielectric withstanding voltage:100V AC
 - 2.5 Insulation Resistance:100MΩ Min
 - 3: Mechanical characteristics:
 - 3.1 Insertion Force:5~20N
 - 3.2 Extraction Force:8~20N
 - 3.3 Durability:10000 cycles
 - 4: Environment characteristics:
 - 4.1 Operating Temperature: -40~+85°C
- Major Dimension:▼
Products meet RoHS environmental requirements

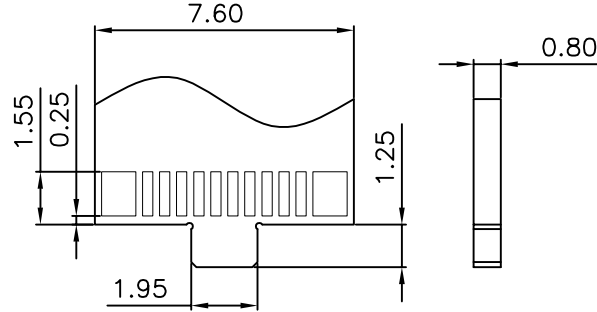
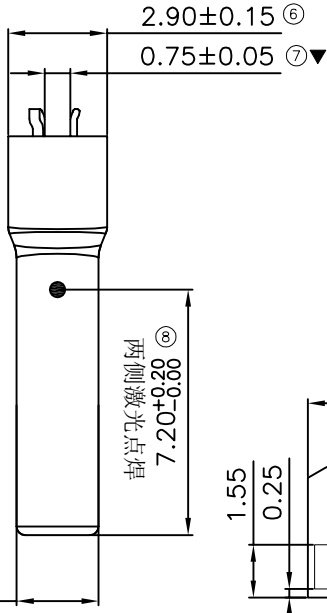
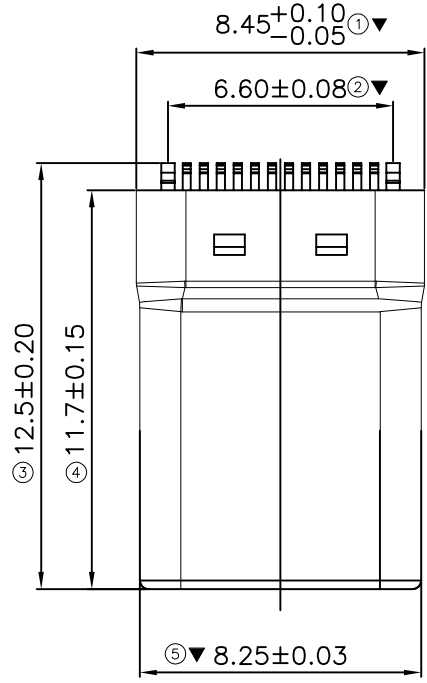
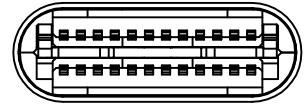

PCB Layout
RECOMMENDED PCB LAYOUT

PIN ASSIGNMENTS

PIN	SIGNAL NAME	PIN	SIGNAL NAME
A1	GND	B12	GND
A2	TX1+	B11	RX1+
A3	TX1-	B10	RX1-
A4	VBUS	B9	VBUS
A5	CC1	B8	SBU2
A6	D+	B7	D-
A7	D-	B6	D+
A8	SBU1	B5	CC2
A9	VBUS	B4	VBUS
A10	TX2-	B3	TX2-
A11	TX2+	B2	TX2+
A12	GND	B1	GND

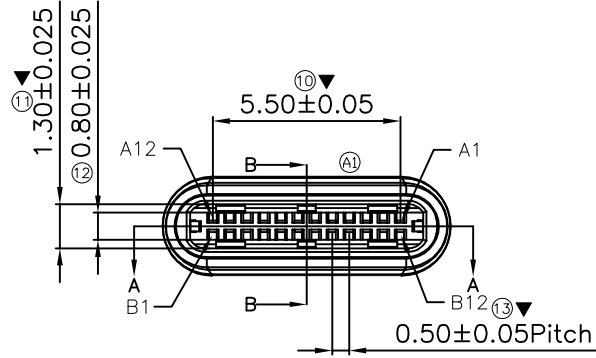

GENERAL TOLERANCE			UNITS	NAME(INTENDED USE)
SELECT	✓		mm	USB
TOL.				
ON.	1	2	3	
X.XXX	±0.10	±0.15	±0.20	PART NO.(INTENDED USE) USB624MC-F2065302
X.XX	±0.15	±0.20	±0.25	
X.X	±0.20	±0.25	±0.30	APPD: Abel
X.	±0.25	±0.30	±0.50	
ANGLE	±2'			CHKD: Vicky
				DR: Ling

ATOM 深圳市爱特姆科技有限公司
SHENZHEN ATOM TECHNOLOGY CO., LTD.

TITLE: Customer Drawing For USB TYPE C 24P MALE 夹板式 L=12.5 (夹板0.75)

DWG NO.: ATOM-A08806

SCALE	SHEET	REV.
1:1	1/1	A1